

# A WIDE CHOICE OF SAWS

**Saws to do the Job.**

**Saws to Boost Your Bottom Line.**

CHOP-CUT, CROSS-CUT AND UP-CUT SAWS  
TO MEET MOST APPLICATIONS.

SERVO OPTION IMPROVES CUTTING  
TOLERANCES, AND ELIMINATES OFF-LINE  
CUTTING COSTS



**Increased Productivity Starts Here**



The easiest-to-use operator interface in the industry. The touchscreen prompts the operator through every step. Not only friendly, it's reliable and durable.



RDN Saws feature chip pans for particle collection.



Saw tables glide on precision-finished rails and linear bearings to ensure smooth travel and increased bearing life.



Up-Cut Saws feature positive clamping for superior cut quality.

## INTELLICUT<sup>®</sup> Servo Option

An advanced servo option produces typical off-line cutting tolerances on-line, eliminating off-line cutting costs. Productivity zooms.

RDN servo saws can contribute to both quality and productivity improvement. By improving cut-length tolerances, you reduce scrap and eliminate the need to re-cut off-line. Set-up time is also reduced because the operator doesn't have to set saw table speed since the table follows the extrudate. This also means that throughout the extrusion run the saw table is always in sync with the extrudate. The servo controller cams the table travel to the product encoder ensuring real time cut length accuracy.

The cut length tolerance of a traveling saw with industry-standard pneumatic operation for the table motion is often +/- 0.125 in. or greater. A tolerance range of +/- 0.015 in. is achievable with RDN's advanced servo option.

## Fully Featured Saws

In addition to being tough and ultra-reliable, all RDN saws are designed to maximize safety, precision, and productivity:

- All RDN saws feature fully guarded operation, as well as chip pans to collect the particulate generated during cutting, keeping work areas safe and clean.
- Smooth table travel with minimum vibration is provided by precision-finished in-line rails and linear motion bearings.
- Chop-Cut Saws have adjustable, polyurethane-faced pneumatic clamps to assure positive hold on the extrudate.
- Up-Cut Saws feature positive clamping straight down on the extrudate with clamps mounted on either side of the saw blade, providing superior cut quality.

# AUTOMATIC TRAVELING SAWS

For rigid and semi-rigid, 2" max. O.D. tubing and profiles, with up to 3" x 6" cross sections. High-speed performance with line speeds up to 25 FPM.



## Chop-Cut Saws: 25 Cuts per Minute!

- Table glides on precision-finished rails and linear motion bearings to ensure smooth travel and increased bearing life. Additional bearings assure table stability.
- Air powered, small saw table provides increased cut speed and capacity.
- Blade travel is smooth, operated with adjustable flow valves to control travel speed. Hydraulic shock absorber cushions return of table.
- Adjustable, polyurethane-faced pneumatic clamps assure positive hold on extrudate.
- Fully guarded operation. Manual cut push button.
- Product counter.
- Chip pan for particle collection.

### SPECIFICATIONS

Model	2418	3618
Type	Chop-Cut	
Cutting Capacity	2" H X 4" W 2" Tube	3" H X 6" W 3" Tube
Saw Blade	10" Diameter	12" Diameter
Center Line Height	42" +/- 2"	
Power Supply	230-460/3/60	
Table Travel	18" 24" Optional	
Motor	1.5 HP	2.0 HP
Air Supply	60-80 PSI	

**A wide variety of options are available.**  
Specifications subject to change without notice.

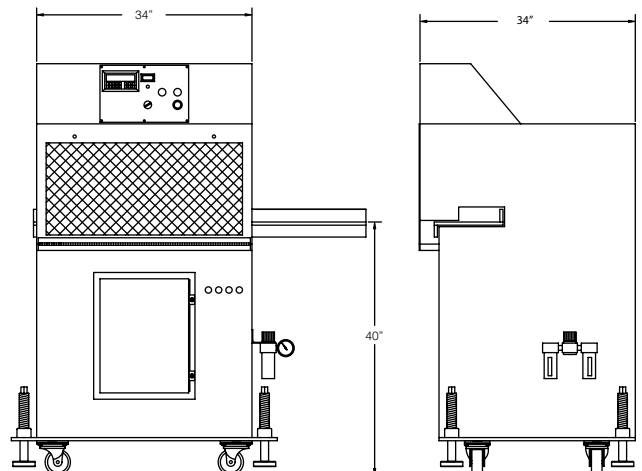

No competitive saw can serve you in so many ways. For automatic in-line cutting of tubing up to 6" x 20" cross sections, semi-rigid and rigid profiles. Line speeds up to 20 FPM. Up to 10 cuts per minute.



## Cross-Cut Saws: Highly Versatile Saw Suits A Wide Range of Applications

- Smooth table travel with minimum vibration and increased bearing life are ensured by providing precision-finished, in-line rails and linear motion bearings. It is air powered in both directions with a hydraulic cushioned return.
- Limit switch adjusts blade travel.
- Saw blade and motor assembly are mounted above the table and travel across the table into the extrudate.
- Positive extrudate clamping with clamps on entrance and exit side of the blade.
- Fully guarded saw blade. AC Blade motor.
- Product counter.
- Chip pan for particle collection.

### SPECIFICATIONS

Model	C-420A	C-430A	C-520A	C620A
Type	Cross-Cut			
Cutting Capacity	4" H X 20" W	4" H X 30" W	5" H X 20" W	6" H X 20" W
Saw Blade	14" Diameter			18" Diameter
Center Line Height	42" +/- 2"			
Power Supply	230-460/3/60			
Table Travel	18" 24" Optional			
Motor	2 HP			3 HP 5 HP Optional
Air Supply	60-80 PSI			

**A wide variety of options are available.**  
Specifications subject to change without notice.

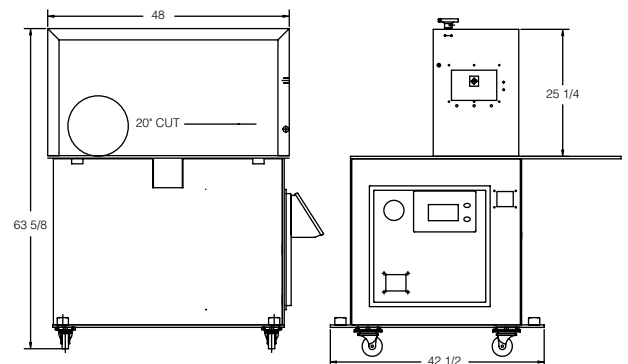
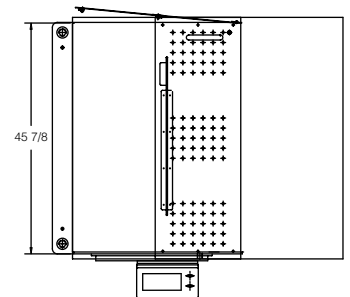



Rigid profile and pipe applications up to 9" O.D. Up to 15 cuts per minute.  
 Lines speeds up to 25 FPM.



## Up-Cut Saws: Proven Dependable Design Assures Productivity

- Smooth table travel, with minimum vibration and increased bearing life are ensured by providing precision-finished, in-line rails and linear motion bearings.
- Tough super reliable, heavy duty saw.
- Needle valves provided for table and saw travel rate.
- Positive clamping, with adjustable air pressure, straight down on the extrudate, with clamps mounted in the saw blade guard on entrance and exit side of the blade provides superior cut quality.
- Fully guarded operation.
- Product counter.
- Choice of four models assures proper cutting capacity.
- Engineered for very quiet operation.

### SPECIFICATIONS

Model	3-18A	5-18A	7-18A	9-18A
Type	Up-Cut			
Cutting Capacity	3" O.D.	5" O.D.	7" O.D.	9" O.D.
Saw Blade	10" Diameter	14" Diameter	20" Diameter	24" Diameter
Center Line Height	42" +/- 2"			
Power Supply	230-460/3/60			
Table Travel	18" 24" Optional			
Motor	1 1/2 HP	2 HP	3 HP	5 HP
Air Supply	60-80 PSI			

**A wide variety of options are available.**  
 Specifications subject to change without notice.

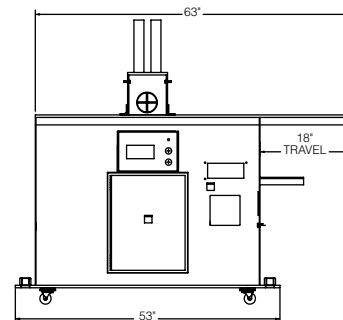
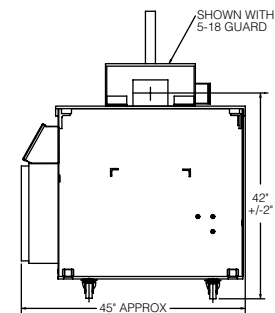



RDN is pleased to offer a complete line of belt pullers, sizing tanks, and calibration tanks to complement our saw lineup. Contact us for more details.



160 Covington Drive  
Bloomington, IL 60108  
PHONE: 630-893-4500  
FAX: 630-893-5010  
[www.rdnmfg.com](http://www.rdnmfg.com)